

3 601 G90 200

Stand } 12-07  
Issue } 12-10-26

**Fig./Abb. 1**

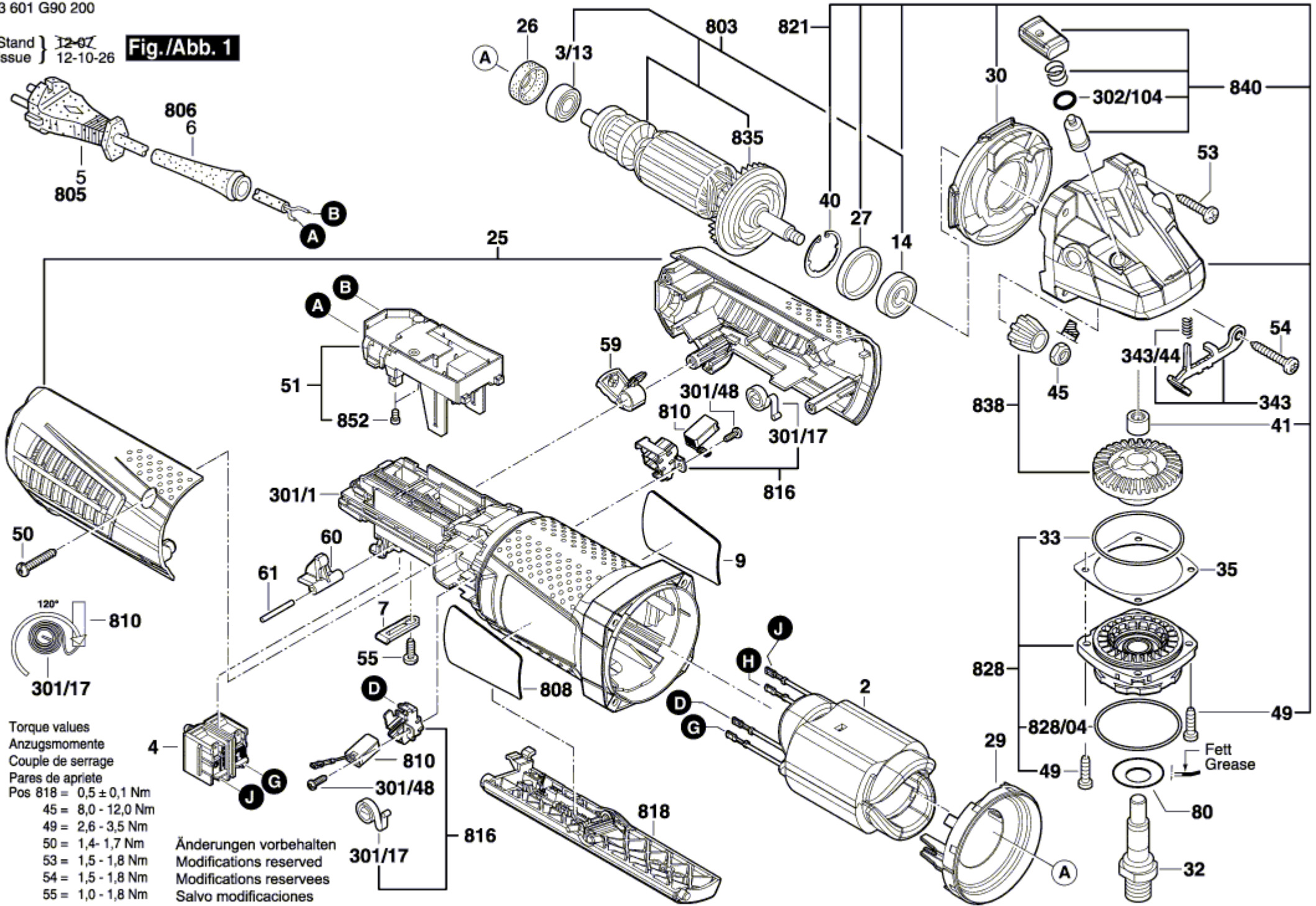

Torque values  
Anzugsmomente  
Couple de serrage  
Pares de apriete

Pos 818 =	0,5 ± 0,1 Nm
45 =	8,0 - 12,0 Nm
49 =	2,6 - 3,5 Nm
50 =	1,4 - 1,7 Nm
53 =	1,5 - 1,8 Nm
54 =	1,5 - 1,8 Nm
55 =	1,0 - 1,8 Nm

Änderungen vorbehalten  
Modifications reserved  
Modifications reservees  
Salvo modificaciones