

3 601 G92 200

Stand } 12-10-26 **Fig./Abb. 1**
 Issue }

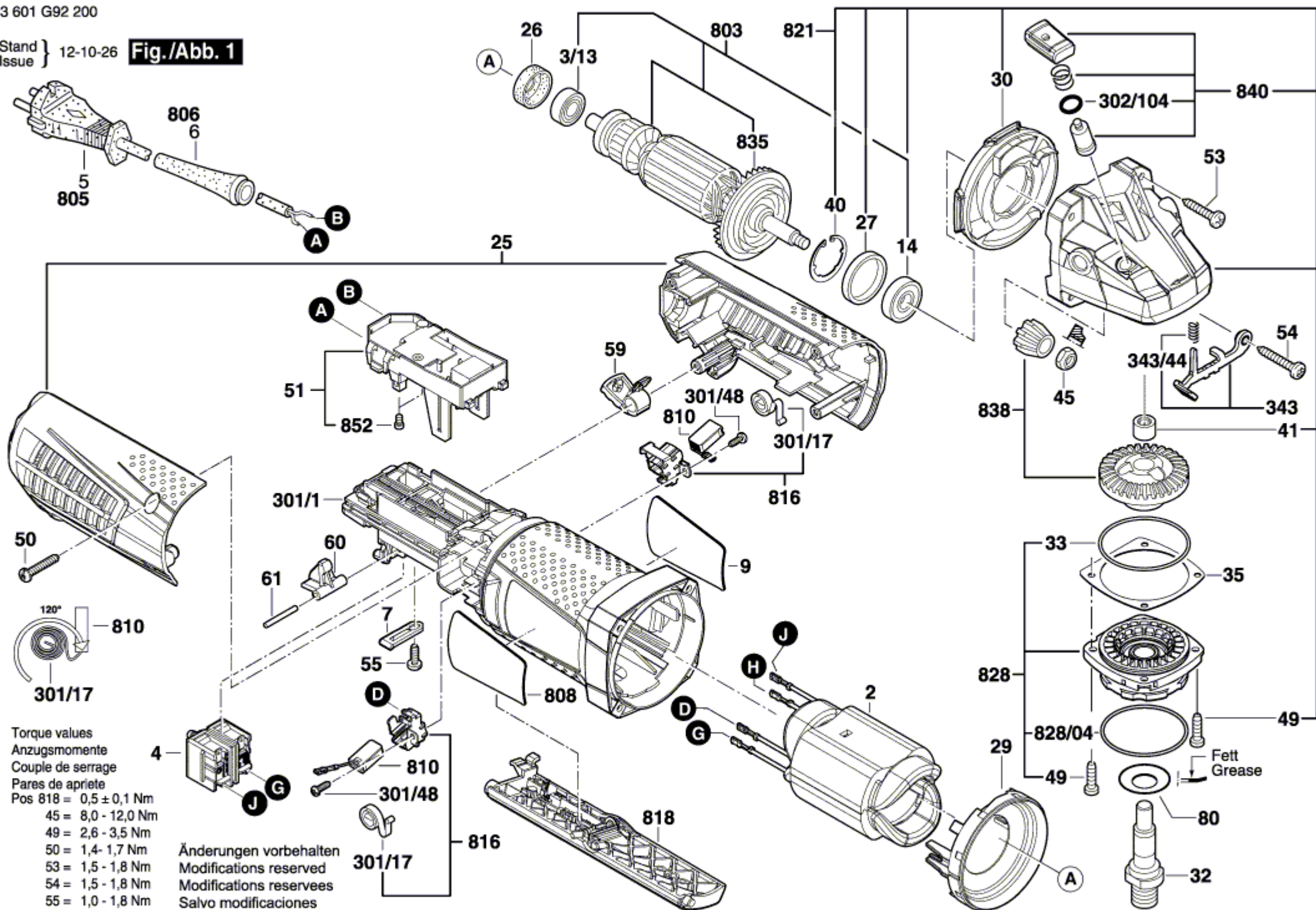

Torque values
 Anzugsmomente
 Couple de serrage
 Pares de apriete

Pos 818	= 0,5 ± 0,1 Nm
45	= 8,0 - 12,0 Nm
49	= 2,6 - 3,5 Nm
50	= 1,4 - 1,7 Nm
53	= 1,5 - 1,8 Nm
54	= 1,5 - 1,8 Nm
55	= 1,0 - 1,8 Nm

Änderungen vorbehalten
 Modifications reserved
 Modifications reservees
 Salvo modificaciones