

3 601 G93 200

Stand } 12-07
Issue } 12-10-26

Fig./Abb. 1

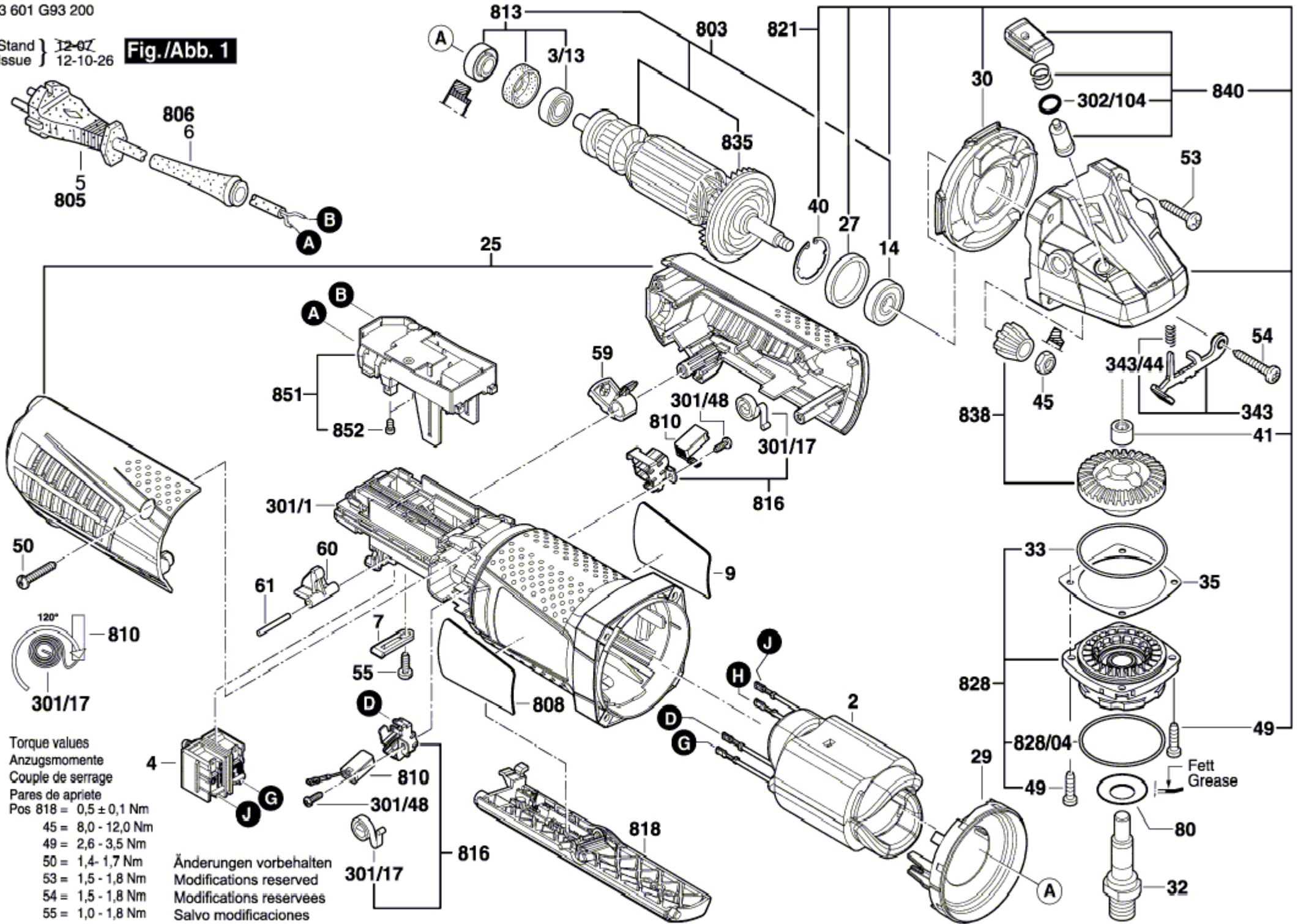

Torque values
Anzugsmomente
Couple de serrage
Pares de apriete

Pos 818 = $0,5 \pm 0,1$ Nm
45 = 8,0 - 12,0 Nm
49 = 2,6 - 3,5 Nm
50 = 1,4 - 1,7 Nm
53 = 1,5 - 1,8 Nm
54 = 1,5 - 1,8 Nm
55 = 1,0 - 1,8 Nm

Änderungen vorbehalten
Modifications reserved
Modifications reservees
Salvo modificaciones