

3 601 G9F 100

Stand } 14-09-30 **Fig./Abb. 1**  
Issue }

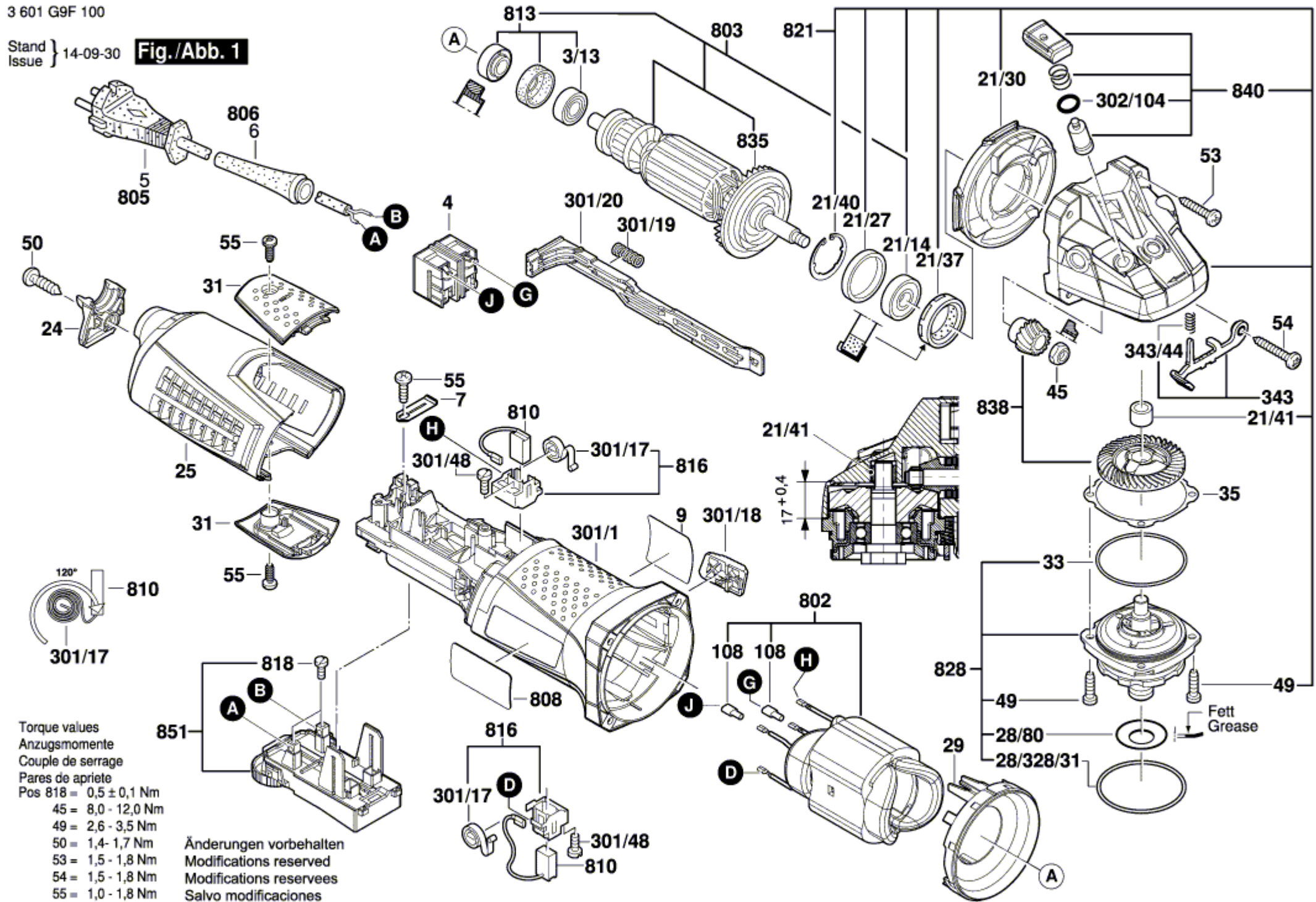

Torque values  
Anzugsmomente  
Couple de serrage  
Pares de apriete  
Pos 818 =  $0,5 \pm 0,1$  Nm  
45 = 8,0 - 12,0 Nm  
49 = 2,6 - 3,5 Nm  
50 = 1,4 - 1,7 Nm  
53 = 1,5 - 1,8 Nm  
54 = 1,5 - 1,8 Nm  
55 = 1,0 - 1,8 Nm

Änderungen vorbehalten  
Modifications reserved  
Modifications reserves  
Salvo modificaciones